



STMPE2401

24-bit Enhanced port expander with Keypad and PWM controller
Xpander logic

Features

- 24 GPIOs
- Operating voltage 1.8V
- Hardware keypad controller (8*12 matrix max)
- 3 PWM (8 bit) output for LED brightness control and blinking
- Interrupt output (open drain) pin
- Configurable hotkey feature on each GPIO
- Ultra-low Standby-mode current
- Package TFBGA - 36 pins 3.6x3.6mm, pitch 0.5mm

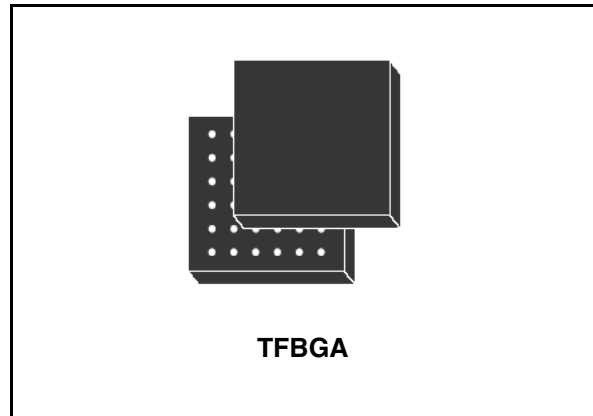

Description

The STMPE2401 is a GPIO (General Purpose Input / output) port expander able to interface a Main Digital ASIC via the two-line bidirectional bus (I2C); separate GPIO Expander IC is often used in Mobile-Multimedia platforms to solve the problems of the limited amounts of GPIOs usually available on the Digital Engine.

The STMPE2401 offers great flexibility as each I/Os is configurable as input, output or specific functions; it's able to scan a keyboard, also provides PWM outputs for brightness control in backlight, rotator decoder interface and GPIO. This device has been designed very low quiescent current, and is including a wake up feature for each I/O, to optimize the power consumption of the IC.

Potential application of the STMPE2401 includes portable media player, game console, mobile phone, smart phone

Figure 1. Device summary

Part number	Package	Packaging
STMPE2401TBR	TFBGA36	Tape and reel

Contents

- 1 Block diagram 5**
- 2 Pin settings 6**
 - 2.1 Pin connection 6
 - 2.2 Pin assignment and TFBGA ball location 6
 - 2.3 GPIO Pin functions 8
 - 2.4 Pin mapping to TFBGA (bottom view, balls up) 9
- 3 Maximum rating 10**
 - 3.1 Absolute maximum rating 10
 - 3.2 Thermal data 10
- 4 Electrical specification 11**
 - 4.1 DC electrical characteristics 11
 - 4.2 I/O DC electrical characteristics 11
 - 4.3 DC input specification 11
 - 4.4 DC output specification 12
 - 4.5 AC characteristics 12
- 5 Register map 13**

6	I2C Interface	14
6.1	Start condition	14
6.2	Stop condition	14
6.3	Acknowledge bit (ACK)	14
6.4	Data input	15
6.5	Slave device address	15
6.6	Memory addressing	15
6.7	Operation modes	16
7	System controller	18
7.1	Identification register	18
7.2	System control register	19
7.3	States of operation	20
8	Clocking system	21
8.1	Programming sequence	21
9	Interrupt system	22
9.1	Register map of interrupt system	22
9.2	Interrupt control register (ICR)	23
9.3	Interrupt enable mask register (IER)	23
9.4	Interrupt status register (ISR)	24
9.5	Interrupt enable GPIO mask register (IEGPIOR)	25
9.6	Interrupt status GPIO register (ISGPIOR)	26
9.7	Programming sequence	27
10	GPIO controller	28
10.1	GPIO control registers	29
10.2	GPIO alternate function register (GPAFR)	30
10.3	Hot key feature	32
10.3.1	Programming sequence for hot key	32
10.3.2	Minimum pulse width	32

11	PWM controller	33
	11.1 Registers in the PWM controller	34
	11.2 PWM control and status register (PWMCS)	35
	11.3 PWM instruction channel x (PWMICx)	36
12	PWM commands	37
13	Keypad controller	40
	13.1 Registers in keypad controller	41
	13.2 KPC_col register	42
	13.3 KPC_row_msb register	42
	13.4 KPC_row_lsb register	43
	13.5 KPC_ctrl_msb register	43
	13.6 KPC_ctrl_lsb register	44
	13.7 Data registers	44
	13.7.1 Resistance	46
	13.7.2 Using the keypad controller	46
14	Rotator controller	47
	14.1 Rotator_Control	48
	14.2 Rotator_Buffer	48
15	Miscellaneous features	50
	15.1 Reset	50
	15.2 Under voltage lockout	50
	15.3 Clock output	50
16	Mechanical data	51
17	Revision history	54

1 Block diagram

Figure 1. Block diagram

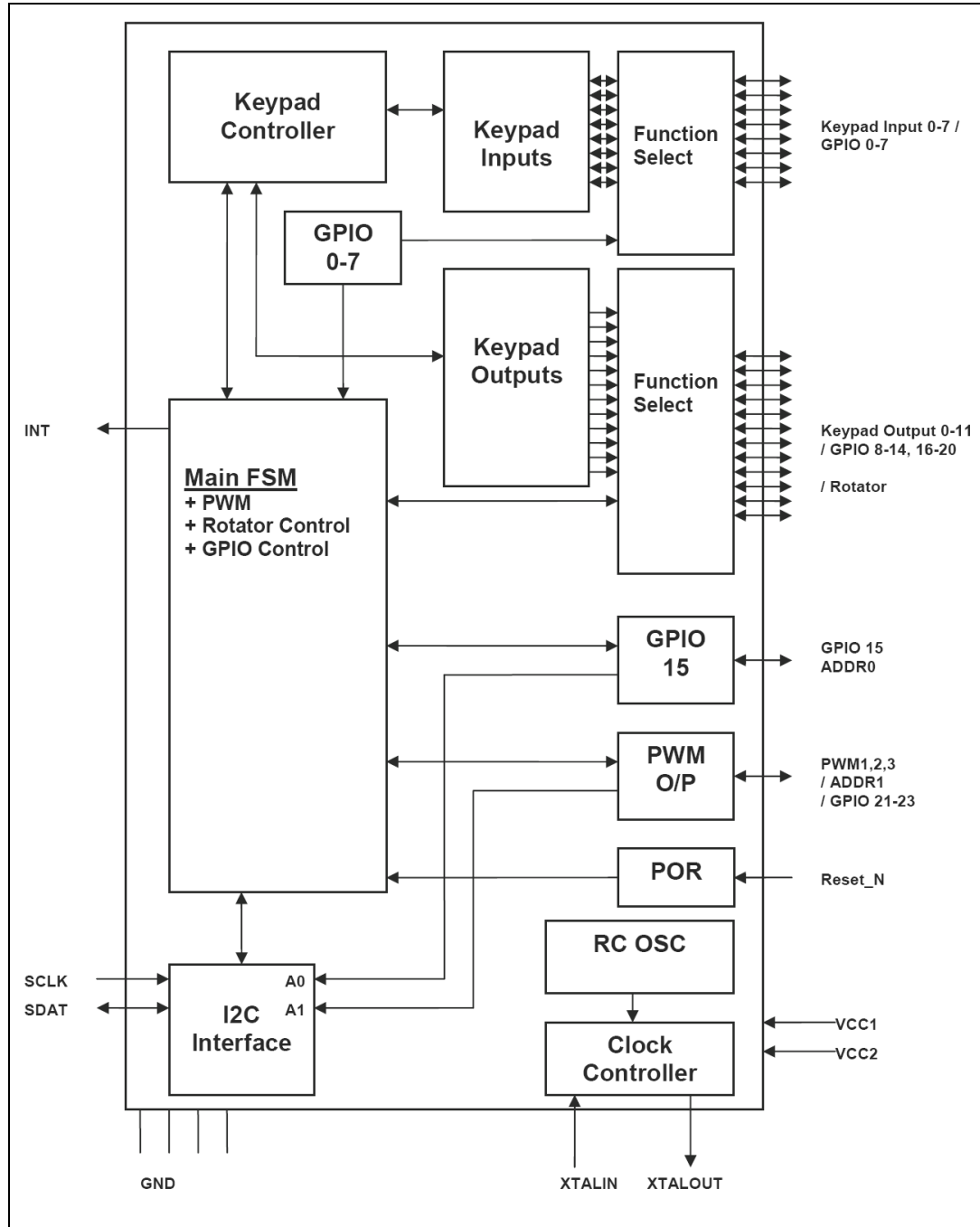

2 Pin settings

2.1 Pin connection

Figure 2. Pin connection

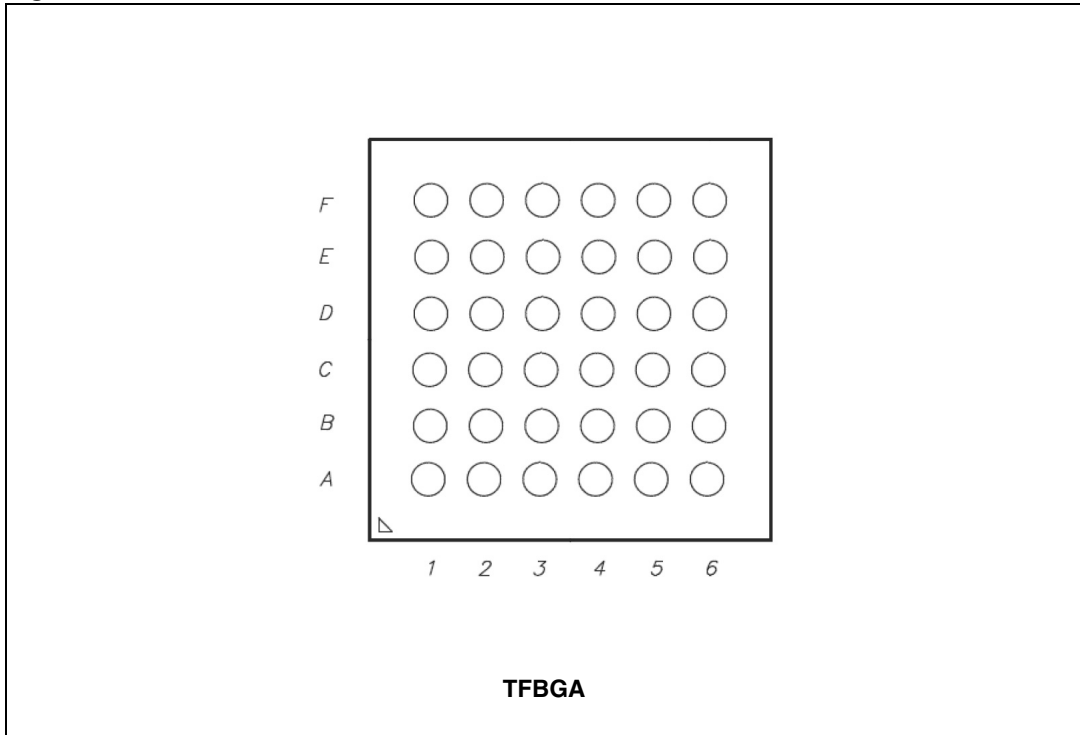

2.2 Pin assignment and TFBGA ball location

Table 1. Pin assignment

Ball	Name	Type	Name and function
C3	GND	-	
C2	KP_X0	IO	GPIO
C1	Reset_N	I	External reset input, active LOW
B1	KP_X1	IO	GPIO
A1	KP_X2	IO	GPIO
B2	KP_X3	IO	GPIO
A2	KP_X4	IO	GPIO
B3	KP_X5	IO	GPIO
A3	KP_X6	IO	GPIO
C4	GND	-	
A4	VCC1	-	1.8V Input

Table 1. Pin assignment

Ball	Name	Type	Name and function
B3	KP_X7	IO	GPIO
A5	KP_Y5	IO	GPIO
A6	KP_Y4	IO	GPIO
B5	KP_Y3	IO	GPIO
B6	KP_Y2	IO	GPIO
C5	KP_Y1	IO	GPIO
C6	KP_Y0	IO	GPIO
D3	GND	-	
D6	ADDR0	IO	GPIO and I2C ADDR 0 (in reset)
D5	KP_Y9	A/IO	GPIO
E6	KP_Y10	A/IO	GPIO
F6	KP_Y11	A/IO	GPIO
E5	PWM3	A/IO	GPIO and I2C ADDR 1 (in reset)
F5	PWM2	A/IO	GPIO
E4	PWM1	A/IO	GPIO
F4	VCC2	-	1.8V Input
D4	GND	-	
F3	INT	O	Open drain interrupt output pin
E3	KP_Y8	IO	GPIO
F2	KP_Y7	IO	GPIO
F1	KP_Y6	IO	GPIO
E2	SDATA	A	I2C DATA
E1	SCLK	A	I2C Clock
D2	XTALIN	A	XTAL Oscillator or External 32KHz input
D1	XTALOUT	A	XTAL Oscillator

2.3 GPIO Pin functions

Table 2. GPIO Pin functions

Pin N°	Name	Primary Function	Alternate Function 1	Alternate Function 2	Alternate Function 3
2	KP_X0	GPIO 0	Keypad input 0		
4	KP_X1	GPIO 1	Keypad input 1		
5	KP_X2	GPIO 2	Keypad input 2		
6	KP_X3	GPIO 3	Keypad input 3		
7	KP_X4	GPIO 4	Keypad input 4		
8	KP_X5	GPIO 5	Keypad input 5		
9	KP_X6	GPIO 6	Keypad input 6		
12	KP_X7	GPIO 7	Keypad input 7		
13	KP_Y5	GPIO 13	Keypad output 5		
14	KP_Y4	GPIO 12	Keypad output 4		
15	KP_Y3	GPIO 11	Keypad output 3		
16	KP_Y2	GPIO 10	Keypad output 2		
17	KP_Y1	GPIO 9	Keypad output 1		
18	KP_Y0	GPIO 8	Keypad output 0		
20	ADDR0	GPIO 15			
21	KP_Y9	GPIO 18	Keypad output 9	Rotator 0	
22	KP_Y10	GPIO 19	Keypad output 10	Rotator 1	
23	KP_Y11	GPIO 20	Keypad output 11	Rotator 2	
24	PWM3	GPIO 23	Channel 3		
25	PWM2	GPIO 22	Channel 2		
26	PWM1	GPIO 21	Channel 1		
30	KP_Y8	GPIO 17	Keypad output 8		ClkOut
31	KP_Y7	GPIO 16	Keypad output 7		
32	KP_Y6	GPIO 14	Keypad output 6		

2.4 Pin mapping to TFBGA (bottom view, balls up)

Table 3. Pin mapping to TFBGA

	A	B	C	D	E	F
1	KP-X2	KP-X1	Reset_N	XTALOUT	SCLK	KP-Y6
2	KP-X4	KP-X3	KP-X0	XTALIN	SDATA	KP-Y7
3	KP-X6	KP-X5	GND	GND	KP-Y8	INT
4	VCC	KP-X7	GND	GND	PWM-1	VCC
5	KP-Y5	KP-Y3	KP-Y1	KP-Y9	PWM-3	PWM-2
6	KP-Y4	KP-Y2	KP-Y0	ADDR0	KP-Y10	KP-Y11

3 Maximum rating

Stressing the device above the rating listed in the “Absolute Maximum Ratings” table may cause permanent damage to the device. These are stress ratings only and operation of the device at these or any other conditions above those indicated in the Operating sections of this specification is not implied. Exposure to Absolute Maximum Rating conditions for extended periods may affect device reliability. Refer also to the STMicroelectronics SURE Program and other relevant quality documents.

3.1 Absolute maximum rating

Table 4. Absolute maximum rating

Symbol	Parameter	Value	Unit
V_{CC}	Supply voltage	2.5	V
V_{IN}	Input voltage on GPIO pin	2.5	V
V_{I2C}	Input voltage on I2C pin (SDATA, SCLK, INT)	4.5	V
VESD (HBM)	ESD protection on each GPIO pin	2	KV

3.2 Thermal data

Table 5. Thermal data

Symbol	Parameter	Min	Typ	Max	Unit
R_{thJA}	Thermal resistance junction-ambient		100		°C/W
T_A	Operating ambient temperature	-40	25	85	°C
T_J	Operating junction temperature	-40	25	125	°C

4 Electrical specification

4.1 DC electrical characteristics

Table 6. DC electrical characteristics

Symbol	Parameter	Test conditions	Value			Unit
			Min.	Typ.	Max.	
VCC1,2	1.8V supply voltage		1.65	1.8	1.95	V
I _{HIBERNATE}	HIBERNATE mode current			6	12	uA
I _{SLEEP}	SLEEP mode current			15	50	uA
I _{CC}	Operating current (FSM working – No peripheral activity)			0.5	1.0	mA
I _{O_INT}	Open drain output current			4		mA
V _{INT}	Voltage level at INT pin			3.6		V

4.2 I/O DC electrical characteristics

The 1.8V I/O complies to the EIA/JEDEC standard JESD8-7.

Table 7. I/O DC electrical characteristic

Symbol	Parameter	Value			Unit
		Min.	Typ.	Max.	
V _{il}	Low level input voltage			0.35*V _{CC} = 0.63	V
V _{ih}	High level input voltage	0.65*V _{CC} = 1.17			V
V _{hyst}	Schmitt trigger hysteresis		0.10		V

4.3 DC input specification

(1.55V < V_{DD} < 1.95V)

Table 8. DC input specification

Symbol	Parameter	Test conditions	Value			Unit
			Min.	Typ.	Max.	
V _{ol}	Low level output voltage	I _{ol} = 4mA			0.45	V
V _{oh}	High level output voltage	I _{oh} = 4mA	V _{CC} - 0.45 = 1.35			V

4.4 DC output specification

(1.55V < vdd < 1.95V)

Table 9. DC output specification

Symbol	Parameter	Test conditions	Value			Unit
			Min.	Typ.	Max.	
I _{pu}	Pull-up current	V _i = 0V	15	35	65	μA
I _{pd}	Pull-down current	V _i = vdd	14	35	60	μA
R _{pu}	Equivalent pull-up resistance	V _i = 0V	30	50	103.3	KΩ
R _{pd}	Equivalent pull-down resistance	V _i = vdd	32.5	50	110.7	KΩ

Note: *Pull-up and Pull-down characteristics*

4.5 AC characteristics

Table 10. AC characteristics

Symbol	Parameter	Value			Unit
		Min.	Typ.	Max.	
F _O	Frequency	16		32	kHz
C _L	Load capacitance			27	pF

5 Register map

All registers have the size of 8-bit. Some of the registers are composed of 2-byte to form 16-bit registers. For each of the module, their registers are residing within the given address range.

Table 11. Register map

Address	Module registers	Description	Auto-Increment (during read/write)
0x00 – 0x07 0x80 – 0x81	Clock and Power Manager module	Clock and Power Manager register range.	Yes
0x10 – 0x1F	Interrupt Controller module	Interrupt Controller register range	Yes
0x30 – 0x37	PWM Controller Module	PWM Controller register range	Yes
0x38 – 0x3F		PWM Controller register range	No
0x60 – 0x67	Keypad Controller Module	Keypad Controller register range	Yes
0x68 – 0x6F		Keypad Controller register range	No
0x70 – 0x77	Rotator Controller Module	Rotator Controller register range	Yes
0x82 – 0xBF	GPIO Controller Module	GPIO Controller register range	Yes

6 I²C Interface

The features that are supported by the I²C interface are as below:

- I²C Slave device
- SDAT and SCLK operates from 1.8V to 3.3V
- Compliant to Philip I²C specification version 2.1
- Supports Standard (up to 100kbps) and Fast (up to 400kbps) modes.
- 7-bit device addressing mode
- General Call
- Start/Restart/Stop
- Address up to 4 STMPE2401 devices via I²C

The address is selected by the state of two pins. The state of the pins will be read upon reset and then the pins can be configured for normal operation. The pins will have a pull-up or down to set the address. The I2C interface module allows the connected host system to access the registers in the STMPE2401.

6.1 Start condition

A Start condition is identified by a falling edge of SDATA while SCLK is stable at high state. A Start condition must precede any data/command transfer. The device continuously monitors for a Start condition and will not respond to any transaction unless one is encountered.

6.2 Stop condition

A Stop condition is identified by a rising edge of SDATA while SCLK is stable at high state. A Stop condition terminates communication between the slave device and bus master. A read command that is followed by NoAck can be followed by a Stop condition to force the slave device into idle mode. When the slave device is in idle mode, it is ready to receive the next I²C transaction. A Stop condition at the end of a write command stops the write operation to registers.

6.3 Acknowledge bit (ACK)

The acknowledge bit is used to indicate a successful byte transfer. The bus transmitter releases the SDATA after sending eight bits of data. During the ninth bit, the receiver pulls the SDATA low to acknowledge the receipt of the eight bits of data. The receiver may leave the SDATA in high state if it would to *not* acknowledge the receipt of the data.

6.4 Data input

The device samples the data input on SDATA on the rising edge of the SCLK. The SDATA signal must be stable during the rising edge of SCLK and the SDATA signal must change only when SCLK is driven low.

6.5 Slave device address

The slave device address is a 7 address, where the least significant 2-bit are programmable. These 2-bit values will be loaded in once upon reset and after that these 2 pins no longer be needed with the exception during General Call. Up to 4 STMPE2401 devices can be connected on a single I²C bus.

Table 12. Slave device address

ADDR 1	ADDR 0	Address
0	0	0x84
0	1	0x86
1	0	0x88
1	1	0x8A

6.6 Memory addressing

For the bus master to communicate to the slave device, the bus master must initiate a Start condition and followed by the slave device address. Accompanying the slave device address, there is a Read/Write bit (R/W). The bit is set to 1 for Read and 0 for Write operation.

If a match occurs on the slave device address, the corresponding device gives an acknowledgement on the SDA during the 9th bit time. If there is no match, it deselects itself from the bus by not responding to the transaction.

6.7 Operation modes

Table 13. Operating modes

Mode	Bytes	Programming sequence
Read	≥1	START, Device Address, $R/\overline{W} = 0$, Register Address to be read
		RESTART, Device Address, $R/\overline{W} = 1$, Data Read, STOP
		If no STOP is issued, the Data Read can be continuously preformed. If the register address falls within the range that allows address auto-increment, then register address auto-increments internally after every byte of data being read. For register address that falls within a non-incremental address range, the address will be kept static throughout the entire read operations. Refer to the Memory Map table for the address ranges that are auto and non-increment. An example of such a non-increment address is FIFO.
Write	≥1	START, Device Address, $R/\overline{W}=0$, Register Address to be written, Data Write, STOP
		If no STOP is issued, the Data Write can be continuously performed. If the register address falls within the range that allows address auto-increment, then register address auto-increments internally after every byte of data being written in. For register address that falls within a non-incremental address range, the address will be kept static throughout the entire write operations. Refer to the Memory Map table for the address ranges that are auto and non-increment. An example of a non-increment address is Data Port for initializing the PWM commands.

Figure 3. Master/slave operation modes

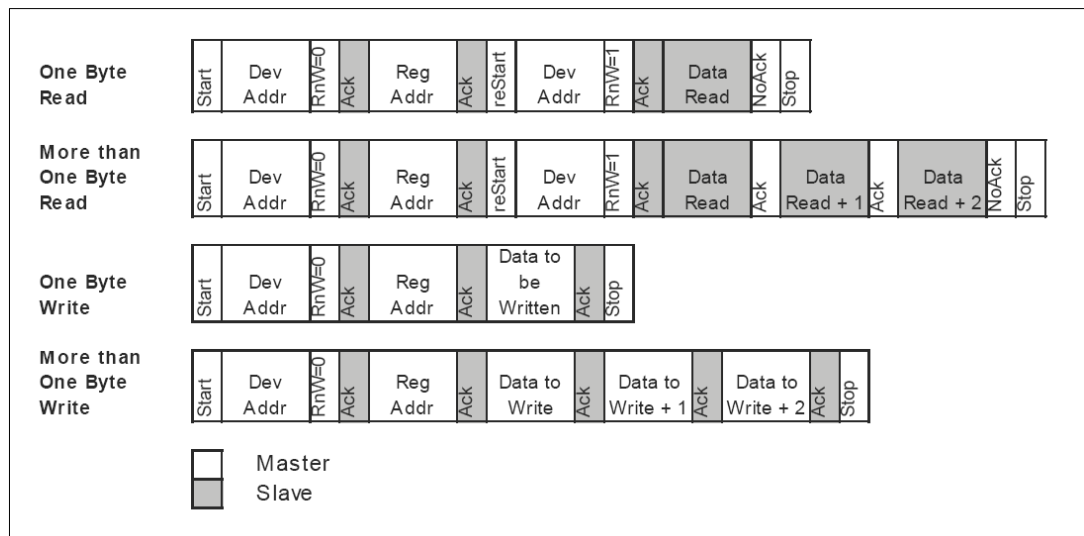

Figure 4. I2C timing

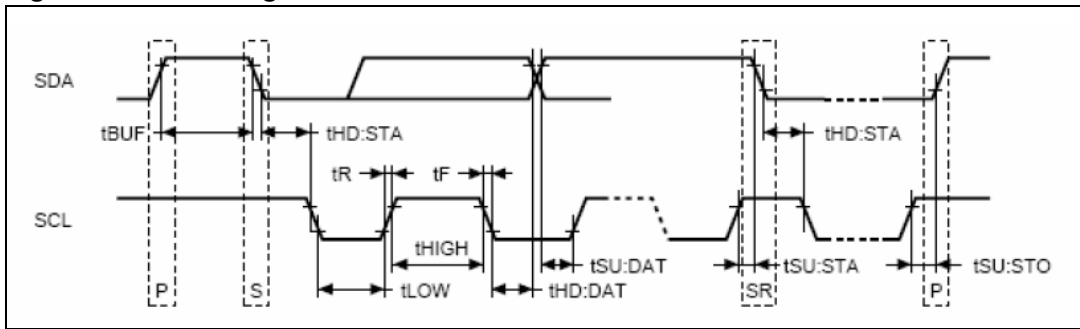

Table 14. I²C address

Symbol	Parameter	Min	Typ	Max	Unit
f_{SCL}	SCL clock frequency	0		400	kHz
t_{LOW}	Clock low period	1.3			μ s
t_{HIGH}	Clock high period	600			ns
t_F	SDA and SCL fall time			300	ns
$t_{HD:STA}$	START condition hold time (After this period the first clock is generated)	600			ns
$t_{SU:STA}$	START condition setup time (Only relevant for a repeated start period)	600			ns
$t_{SU:DAT}$	Data setup time	100			ns
$t_{HD:DAT}$	Data hold time	0			μ s
$t_{SU:STO}$	STOP condition setup time	600			ns
t_{BUF}	Time the bust must be free before a new trasmission can start	1.3			μ s

7 System controller

The system controller is the heart of the STMPE2401. It contains the registers for power control, and the registers for chip identification.

The system registers are:

Table 15. System controller

<u>Address</u>	<u>Register Name</u>
0x00	Reserved (Reads 0x00)
0x01	Reserved (Reads 0x00)
0x80	CHIP_ID
0x81	VERSION_ID
0x82	Reserved (Reads 0x00)
0x02	SYSCON

7.1 Identification register

Table 16. CHIP_ID

Bit	7	6	5	4	3	2	1	0
8-bit LSB of Chip ID								
Read/Write(IIC)	R	R	R	R	R	R	R	R
Reset Value	0	0	0	0	0	0	0	1

Table 17. VERSION_ID

Bit	7	6	5	4	3	2	1	0
8-bit Version ID								
Read/Write(IIC)	R	R	R	R	R	R	R	R
Reset Value	0	0	0	0	0	0	0	1

7.2 System control register

Table 18. System control register

Bit	7	6	5	4	3	2	1	0
	Soft_Reset	-	Disable_32KHz	Sleep	Enable_GPIO	Enable_PWM	Enable_KPC	Enable_ROT
Read/Write (IIC)	W		RW	RW	RW	RW	RW	RW
Read/Write(HW)	RW		R	RW	R	R	R	R
Reset Value	0		0	0	1	1	1	1

Table 19. System control register writing

Bits	Name	Description
0	Enable_ROT	Writing a '0' to this bit will gate off the clock to the Rotator module, thus stopping its operation
1	Enable_KPC	Writing a '0' to this bit will gate off the clock to the Keypad Controller module, thus stopping its operation
2	Enable_PWM	Writing a '0' to this bit will gate off the clock to the PWM module, thus stopping its operation
3	Enable_GPIO	Writing a '0' to this bit will gate off the clock to the GPIO module, thus stopping its operation
4	Sleep	Writing a '1' to this bit will put the device in sleep mode. When in sleep mode, all the units which need to work on clocks synchronous to 32KHz will get the clocks derived from the 32K domain. The RC Oscillator will be shut off.
5	Disable_32KHz	Set this bit to disable the 32KHz OSC, thus putting the device in hibernate mode. Only a Reset or a wakeup on IIC will reset this bit
6	-	-
7	Soft_Reset	Writing a '1' to this bit will do a soft reset of the device. Once the reset is done, this bit will be cleared to '0' by the HW.

7.3 States of operation

The device has three main modes of operation:

- **Operational Mode:** This is the mode, whereby normal operation of the device takes place. In this mode, the RC clock is available and the Main FSM Unit routes this clock and the 32 KHz clock to all the device blocks that are enabled. In this mode, individual blocks that need not be working can be turned off by the master by programming the bits 3 to 0 of the SYSCON register.
- **Sleep Mode:** In this low-power mode, the RC Oscillator is powered down. All the blocks which need clocks derived from the 32KHz clock will continue getting a 32KHz clock. In this mode also, individual blocks can be turned off by the master by programming the bits 3 to 0 of the SYSCON register. However, the master needs to program the SYSCON register before coming into this mode, as in the sleep mode, the IIC interface is not active except to detect traffic for wakeup. Any activity on the I2C port or Wakeup pin or Hotkey activity will cause the device to leave this mode and go into the Operational mode. When leaving this mode, the I2C will need to hold the SCLK till the RC clock is ready.
- **Hibernate Mode:** This mode is entered when the system writes a '1' to bit 5 of the SYSCON register. In this mode, the device is completely inactive as there is absolutely no clock. Only a Reset or a wakeup on IIC will bring back the System to operational mode. All I2C activities are ignored.

Caution: Hotkey detection is not possible in hibernate mode.

Figure 5. State of operation

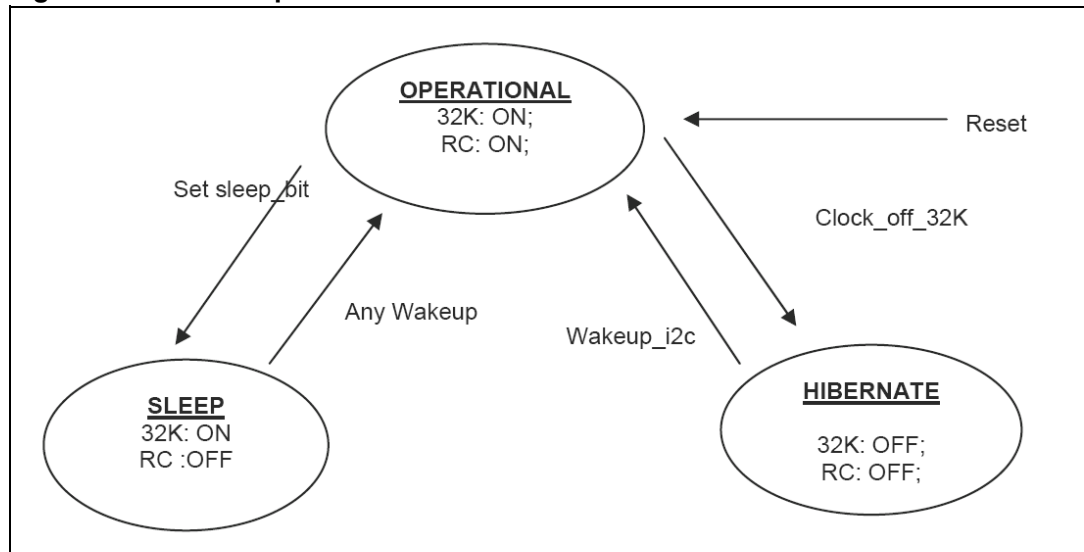

8 Clocking system

Figure 6. Clocking system

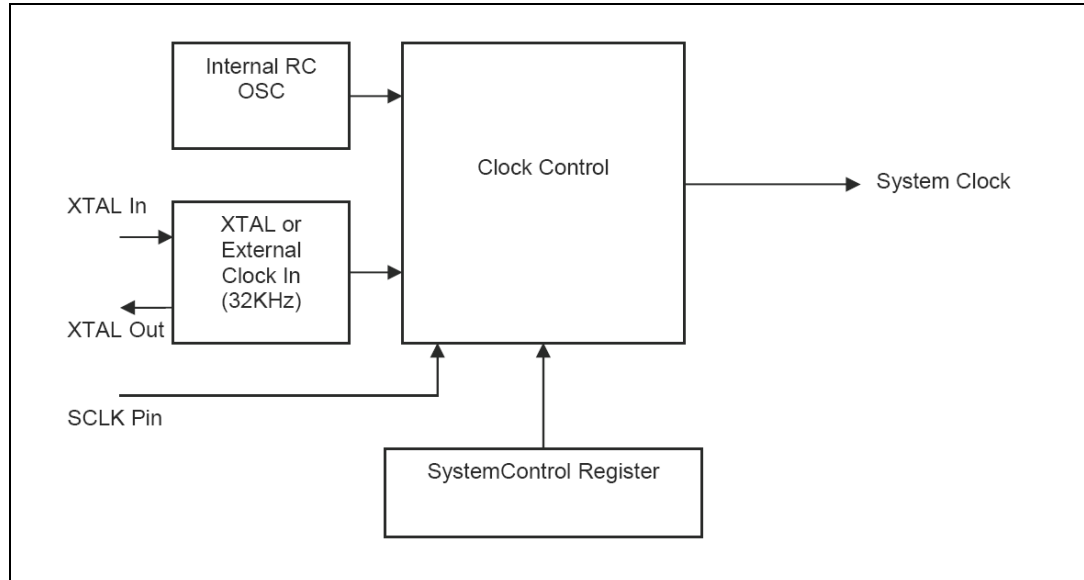

The decision on clocks is based on the bits written into SYSCON registers. Bits 0 to 4 of the SYSCON register control the gating of clocks to the Rotator, Keypad Controller, PWM and GPIO respectively in the operational mode. When in sleep mode, the operating clock is cut off from every functional blocks (including the I²C) except Keypad Controller and GPIO.

8.1 Programming sequence

To put the device in sleep mode, the following needs to be done by the host:

1. Write a '1' to bit 4 of the SYSCON register.
2. To wakeup the device, the following needs to be done by the host:
3. Assert a wakeup routine on the I²C bus by sending the Start Bit, followed by the device address and the R/W bit.
4. If there's a NOACK, keep sending the wakeup routine till there is an ACK from the slave.
5. To do a soft reset to the device, the host needs to do the following:
6. Write a '1' to bit 7 of the SYSCON register.
7. This bit is automatically cleared upon reset.
8. To go into Hibernate mode, the following needs to be done by the host:
9. Set the Disable_32K bit to '1'
10. To come out of the Hibernate mode, the following needs to be done by the host:
11. Assert a system reset or
12. Put a wakeup on the I²C

9 Interrupt system

STMPE2401 uses a highly flexible interrupt system. It allows host system to configure the type of system events that should result in an interrupt, and pinpoints the source of interrupt by status register. The INT pin could be configured as ACTIVE HIGH, or ACTIVE LOW. 32KHz clock input or crystal must be available for the interrupt system to be functional.

INT pin is 3.3V tolerant.

Once asserted, the INT pin would de-assert only if the corresponding bit in the InterruptStatus register is cleared.

Figure 7. Interrupt system

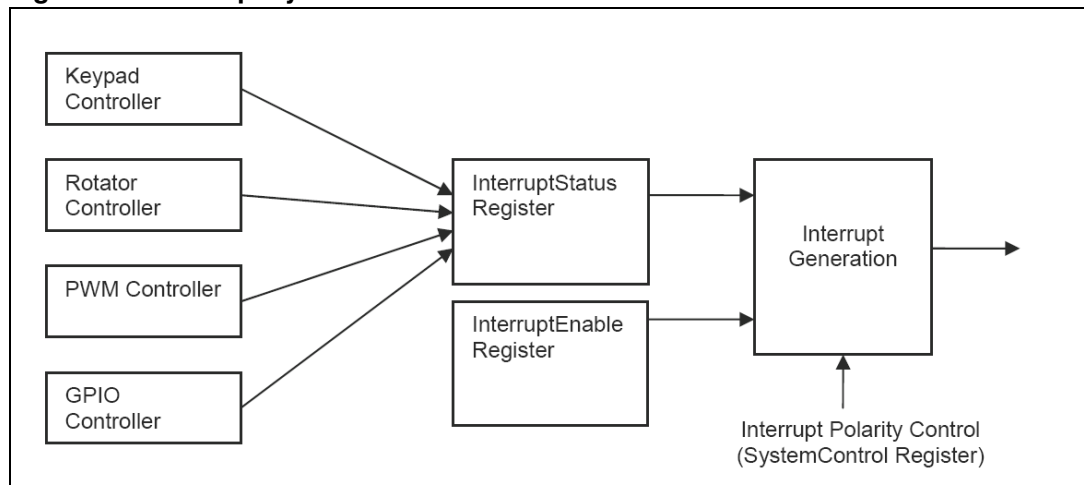

9.1 Register map of interrupt system

Table 20. Register map of interrupt system

Address	Register Name	Description	Auto-Increment (during sequential R/W)
0x10	ICR_msb	Interrupt Control Register	Yes
0x11	ICR_lsb		Yes
0x12	IER_msb	Interrupt Enable Mask Register	Yes
0x13	IER_lsb		Yes
0x14	ISR_msb	Interrupt Status Register	Yes
0x15	ISR_lsb		Yes
0x16	IEGPIOR_msb	Interrupt Enable GPIO Mask Register	Yes
0x17	IEGPIOR_mid		Yes
0x18	IEGPIOR_lsb		Yes
0x19	ISGPIOR_msb	Interrupt Status GPIO Register	Yes
0x1A	ISGPIOR_mid		Yes
0x1B	ISGPIOR_lsb		Yes

9.2 Interrupt control register (ICR)

ICR register is used to configure the Interrupt Controller. It has a global enable interrupt mask bit that controls the interruption to the host.

Bit	ICR_msb										ICR_lsb					
	15	14	13	12	11	10	9	8	7	6	5	4	3	2	1	0
	Reserved										IC2	IC1	IC0			
R/W	R	R	R	R	R	R	R	R	R	R	R	R	R	RW	RW	RW
Reset Value	0	0	0	0	0	0	0	0	0	0	0	0	0	0	0	0

Table 21. ICR

Bits	Name	Description
0	IC[0]	Global Interrupt Mask bit When this bit is written a '1', it will allow interruption to the host. If it is written with a '0', then, it disables all interruption to the host. Writing to this bit does not affect the IER value.
1	IC[1]	output Interrupt Type '0' = Level interrupt '1' = Edge interrupt
2	IC[2]	output Interrupt Polarity '0' = Active Low / Falling Edge '1' = Active High / Rising Edge

9.3 Interrupt enable mask register (IER)

IER register is used to enable the interruption from a particular interrupt source to the host.

Bit	IER_msb								IER_lsb								
	15	14	13	12	11	10	9	8	7	6	5	4	3	2	1	0	
	Reserved								IE8	IE7	IE6	IE5	IE4	IE3	IE2	IE1	IE0
R/W	R	R	R	R	R	R	R	RW	RW	RW	RW	RW	RW	RW	RW	RW	
Reset Value	0	0	0	0	0	0	0	0	0	0	0	0	0	0	0	0	

Table 22. IER

Bits	Name	Description
8:0	IE[x]	Interrupt Enable Mask (where x = 8 to 0) IE0 = Wake-up Interrupt Mask IE1 = Keypad Controller Interrupt Mask IE2 = Keypad Controller FIFO Overflow Interrupt Mask IE3 = Rotator Controller Interrupt Mask IE4 = Rotator Controller Buffer Overflow Interrupt Mask IE5 = PWM Channel 0 Interrupt Mask IE6 = PWM Channel 1 Interrupt Mask IE7 = PWM Channel 2 Interrupt Mask IE8 = GPIO Controller Interrupt Mask Writing a '1' to the IE[x] bit will enable the interruption to the host.

9.4 Interrupt status register (ISR)

ISR register monitors the status of the interruption from a particular interrupt source to the host. Regardless whether the IER bits are enabled or not, the ISR bits are still updated.

Bit	ISR_msb								ISR_lsb								
	15	14	13	12	11	10	9	8	7	6	5	4	3	2	1	0	
	Reserved								IS8	IS7	IS6	IS5	IS4	IS3	IS2	IS1	IS0
R/W	R	R	R	R	R	R	R	RW	RW	RW	RW	RW	RW	RW	RW	RW	
Reset Value	0	0	0	0	0	0	0	0	0	0	0	0	0	0	0	0	

Table 23. ISR

Bits	Name	Description
8:0	IS[x]	Interrupt Status (where x = 8 to 0) Read: IS0 = Wake-up Interrupt Status IS1 = Keypad Controller Interrupt Status IS2 = Keypad Controller FIFO Overflow Interrupt Status IS3 = Rotator Controller Interrupt Status IS4 = Rotator Controller Buffer Overflow Interrupt Status IS5 = PWM Channel 0 Interrupt Status IS6 = PWM Channel 1 Interrupt Status IS7 = PWM Channel 2 Interrupt Status IS8 = GPIO Controller Interrupt Status Write: A write to a IS[x] bit with a value of '1' will clear the interrupt and a write with a value of '0' has no effect on the IS[x] bit.

9.5 Interrupt enable GPIO mask register (IEGPIOR)

IEGPIOR register is used to enable the interruption from a particular GPIO interrupt source to the host. The IEG[15:0] bits are the interrupt enable mask bits correspond to the GPIO[15:0] pins.

		IEGPIOR_msb							
Bit		23	22	21	20	19	18	17	16
		IEG 23	IEG 22	IEG 21	IEG 20	IEG 19	IEG 18	IEG 17	IEG 16
R/W		RW	RW	RW	RW	RW	RW	RW	RW
Reset Value		0	0	0	0	0	0	0	0

		IEGPIOR_lsb															
Bit		15	14	13	12	11	10	9	8	7	6	5	4	3	2	1	0
		IEG 15	IEG 14	IEG 13	IEG 12	IEG 11	IEG 10	IEG 9	IEG 8	IEG 7	IEG 6	IEG 5	IEG 4	IEG 3	IEG 2	IEG 1	IEG 0
R/W		RW	RW	RW	RW	RW	RW	RW	RW	RW	RW	RW	RW	RW	RW	RW	RW
Reset Value		0	0	0	0	0	0	0	0	0	0	0	0	0	0	0	0

Table 24. GPIO

Bits	Name	Description
23:0	IEG[x]	Interrupt Enable GPIO Mask (where x = 23 to 0) Writing a '1' to the IE[x] bit will enable the interruption to the host.

9.6 Interrupt status GPIO register (ISGPIOR)

ISGPIOR register monitors the status of the interruption from a particular GPIO pin interrupt source to the host. Regardless whether the IEGPIOR bits are enabled or not, the ISGPIOR bits are still updated. The ISG[15:0] bits are the interrupt status bits correspond to the GPIO[15:0] pins.

		ISGPIOR_lsb							
Bit		23	22	21	20	19	18	17	16
		IEG 23	IEG 22	IEG 21	IEG 20	IEG 19	IEG 18	IEG 17	IEG 16
R/W		RW	RW	RW	RW	RW	RW	RW	RW
Reset Value		0	0	0	0	0	0	0	0

		ISGPIOR_msb								ISGPIOR_lsb							
Bit		15	14	13	12	11	10	9	8	7	6	5	4	3	2	1	0
		ISG 15	ISG 14	ISG 13	ISG 12	ISG 11	ISG 10	ISG 9	ISG 8	ISG 7	ISG 6	ISG 5	ISG 4	ISG 3	ISG 2	ISG 1	ISG 0
R/W		RW	RW	RW	RW	RW	RW	RW	RW	RW	RW	RW	RW	RW	RW	RW	RW
Reset Value		0	0	0	0	0	0	0	0	0	0	0	0	0	0	0	0

Table 25. GPIO

Bits	Name	Description
23:0	ISG[x]	Interrupt Status GPIO (where x = 23 to 0) Read: Interrupt Status of the GPIO[x]. Write: A write to a ISG[x] bit with a value of '1' will clear the interrupt and a write with a value of '0' has no effect on the ISG[x] bit.

9.7 Programming sequence

To configure and initialize the Interrupt Controller to allow interruption to host, observe the following steps:

- Set the IER and IEGPIOR registers to the desired values to enable the interrupt sources that are to be expected to receive from.
- Configure the output interrupt type and polarity and enable the global interrupt mask by writing to the ICR.
- Wait for interrupt.
- Upon receiving an interrupt, the INT pin is asserted.
- The host comes to read the ISR through I²C interface. A '1' in the ISR bits indicates that the corresponding interrupt source is triggered.
- If the IS8 bit in ISR is set, the interrupt is coming from the GPIO Controller. Then, a subsequent read is performed on the ISGPIOR to obtain the interrupt status of all 16 GPIOs to locate the GPIO that triggers the interrupt. This is a feature so-called 'Hot Key'.
- After obtaining the interrupt source that triggers the interrupt, the host performs the necessary processing and operations related to the interrupt source.
- If the interrupt source is from the GPIO Controller, two write operations with value of '1' are performed to the ISG[x] bit (ISGPIOR) and the IS[8] (ISR) to clear the corresponding GPIO interrupt.
- If the interrupt source is from other module, a write operation with value of '1' is performed to the IS[x] (ISR) to clear the corresponding interrupt.
- Once the interrupt is being cleared, the INT pin will also be de-asserted if the interrupt type is level interrupt. An edge interrupt will only assert a pulse width of 250ns.
- When the interrupt is no longer required, the IC0 bit in ICR may be set to '0' to disable the global interrupt mask bit.

10 GPIO controller

A total of 24 GPIOs are available in the STMPE2401 port expander IC. Most of the GPIOs are sharing physical pins with some alternate functions. The GPIO controller contains the registers that allow the host system to configure each of the pins into either a GPIO, or one of the alternate functions. Unused GPIOs should be configured as outputs to minimize the power consumption.

Table 26. GPIO controller

Address	Register name	Description	Auto-Increment (during sequential R/W)
0xA2	GPMR_msb	GPIO Monitor Pin State Register	Yes
0xA3	GPMR_csb		Yes
0xA4	GPMR_lsb		Yes
0x83	GPSR_msb	GPIO Set Pin State Register	Yes
0x84	GPSR_csb		Yes
0x85	GPSR_lsb		Yes
0x86	GPCR_msb	GPIO Clear Pin State Register	Yes
0x87	GPCR_csb		Yes
0x88	GPCR_lsb		Yes
0x89	GPDR_msb	GPIO Set Pin Direction Register	Yes
0x8A	GPDR_csb		Yes
0x8B	GPDR_lsb		Yes
0x8C	GPEDR_msb	GPIO Edge Detect Status Register	Yes
0x8D	GPEDR_csb		Yes
0x8E	GPEDR_lsb		Yes
0x8F	GPRER_msb	GPIO Rising Edge Register	Yes
0x90	GPRER_csb		Yes
0x91	GPRER_lsb		Yes
0x92	GPFER_msb	GPIO Falling Edge Register	Yes
0x93	GPFER_csb		Yes
0x94	GPFER_lsb		Yes
0x95	GPPUR_msb	GPIO Pull Up Register	Yes
0x96	GPPUR_csb		Yes
0x97	GPPUR_lsb		Yes
0x98	GPPDR_msb	GPIO Pull Down Register	Yes
0x99	GPPDR_csb		Yes
0x9A	GPPDR_lsb		Yes

Table 26. GPIO controller

Address	Register name	Description	Auto-Increment (during sequential R/W)
0x9B	GPAFR_U_msb	GPIO Alternate Function Register (Upper Bit)	Yes
0x9C	GPAFR_U_csb		Yes
0x9D	GPAFR_U_lsb		Yes
0x9E	GPAFR_L_msb	GPIO Alternate Function Register (Lower Bit)	Yes
0x9F	GPAFR_L_csb		Yes
0xA0	GPAFR_L_lsb		Yes
0xA5 – 0xAF	RESERVED	Reserved	Yes

10.1 GPIO control registers

A group of registers are used to control the exact function of each of the 24 GPIO. All GPIO registers are named as GPxxx_yyy, where

Xxx represents the functional group

Yyy represents the byte position of the GPIO

Lsb registers controls GPIO[7:0]

Csb registers controls GPIO[15:8]

Msb registers controls GPIO[23:16]

Table 27. Register

Bit	7	6	5	4	3	2	1	0
GPxxx_msb	IO-23	IO-22	IO-21	IO-20	IO-19	IO-18	IO-17	IO-16
GPxxx_csb	IO-15	IO-14	IO-13	IO-12	IO-11	IO-10	IO-9	IO-8
GPxxx_lsb	IO-7	IO-6	IO-5	IO-4	IO-3	IO-2	IO-1	IO-0

Note: This convention does not apply to the GPIO Alternate Function Registers

The function of each bit is shown in the following table:

Table 28. Bit's function

Register name	Function
GPIO Monitor Pin State	Reading this bit yields the current state of the bit. Writing has no effect.
GPIO Set Pin State	Writing '1' to this bit causes the corresponding GPIO to go to '1' state. Writing '0' has no effect.
GPIO Clear Pin State	Writing '1' to this bit causes the corresponding GPIO to go to '0' state. Writing '0' has no effect.
GPIO Set Pin Direction	'0' sets the corresponding GPIO to input state, and '1' sets it to output state

Table 28. Bit's function

Register name	Function
GPIO Edge Detect Status	Set to '1' by hardware when there is a rising/falling edge on the corresponding GPIO. Writing '1' clears the bit. Writing '0' has no effect.
GPIO Rising Edge	Set to '1' to enable rising edge detection on the corresponding GPIO.
GPIO Falling Edge	Set to '1' to enable falling edge detection on the corresponding GPIO.
GPIO Pull Up	Set to '1' to enable internal pull-up resistor
GPIO Pull Down	Set to '1' to enable internal pull-down resistor

10.2 GPIO alternate function register (GPAFR)

GPAFR is to select the functionality of the GPIO pin. To select a function for a GPIO pin, a bit-pair in the register (GPAFR_U or GPAFR_L) has to be set.

	GPAFR_U_msb							
Bit	23	22	21	20	19	18	17	16
	AF23		AF22		AF21		AF20	
R/W	RW	RW	RW	RW	RW	RW	RW	RW
Reset Value	0	0	0	0	0	0	0	0
	GPAFR_U_csb							
Bit	15	14	13	12	11	10	9	8
	AF19		AF18		AF17		AF16	
R/W	RW	RW	RW	RW	RW	RW	RW	RW
Reset Value	0	0	0	0	0	0	0	0
	GPAFR_U_lsb							
Bit	7	6	5	4	3	2	1	0
	AF15		AF14		AF13		AF12	
R/W	RW	RW	RW	RW	RW	RW	RW	RW
Reset Value	0	0	0	0	0	0	0	0

Table 29. Bit description

Bits	Name	Description
23:0	AF[x]	GPIO Pin 'x' Alternate Function Select (where x = 23 to 12). '00' – The corresponding GPIO pin (GPIO[x]) is configured to Primary Function. '01' – The corresponding GPIO pin (GPIO[x]) is configured to Alternate Function 1. '10' – The corresponding GPIO pin (GPIO[x]) is configured to Alternate Function 2. '11' – The corresponding GPIO pin (GPIO[x]) is configured to Alternate Function 3.

	GPAFR_L_msb							
Bit	23	22	21	20	19	18	17	16
	AF11		AF10		AF9		AF8	
R/W	RW	RW	RW	RW	RW	RW	RW	RW
Reset Value	0	0	0	0	0	0	0	0
	GPAFR_L_csb							
Bit	15	14	13	12	11	10	9	8
	AF7		AF6		AF5		AF4	
R/W	RW	RW	RW	RW	RW	RW	RW	RW
Reset Value	0	0	0	0	0	0	0	0
	GPAFR_L_lsb							
Bit	7	6	5	4	3	2	1	0
	AF3		AF2		AF1		AF0	
R/W	RW	RW	RW	RW	RW	RW	RW	RW
Reset Value	0	0	0	0	0	0	0	0

Table 30. Bit description

Bits	Name	Description
23:0	AF[x]	GPIO Pin 'x' Alternate Function Select (where x = 11 to 0). '00' – The corresponding GPIO pin (GPIO[x]) is configured to Primary Function. '01' – The corresponding GPIO pin (GPIO[x]) is configured to Alternate Function 1. '10' – The corresponding GPIO pin (GPIO[x]) is configured to Alternate Function 2. '11' – The corresponding GPIO pin (GPIO[x]) is configured to Alternate Function 3.

10.3 Hot key feature

A GPIO is known as 'Hot Key' when it is configured to trigger an interruption to the host whenever the GPIO input is being asserted. This feature is applicable in Operational mode (RC clock is present) as well as Sleep mode (32kHz clock is present).

10.3.1 Programming sequence for hot key

1. Configures the GPIO pin into GPIO mode by setting the corresponding bits in the GPAFR.
2. Configures the GPIO pin into input direction by setting the corresponding bit in GPDR.
3. Set the GPRER and GPFER to the desired values to enable the rising edge or falling edge detection.
4. Configures and enables the interrupt controller to allow the interruption to the host.
5. Now, the GPIO Expander may be put into Sleep mode if it is desired.
6. Upon any Hot Key being asserted, the device will wake-up and issue an interrupt to the host.

Below are the conditions to be fulfilled in order to configure a Hot Key:

1. The pin is configured into GPIO mode and as input pin.
2. The global interrupt mask bit is enabled.
3. The corresponding GPIO interrupt mask bit is enabled.

10.3.2 Minimum pulse width

The minimum pulse width of the assertion of the Hot Key must be at least 62.5us. Any pulse width less than the stated value may not be registered.

11 PWM controller

The STMPE2401 PWM controller provides 3 independent PWM outputs used to generate light effect; if the PWM outputs are not used, these pins can be used as GPIO.

Figure 8. PWM controller

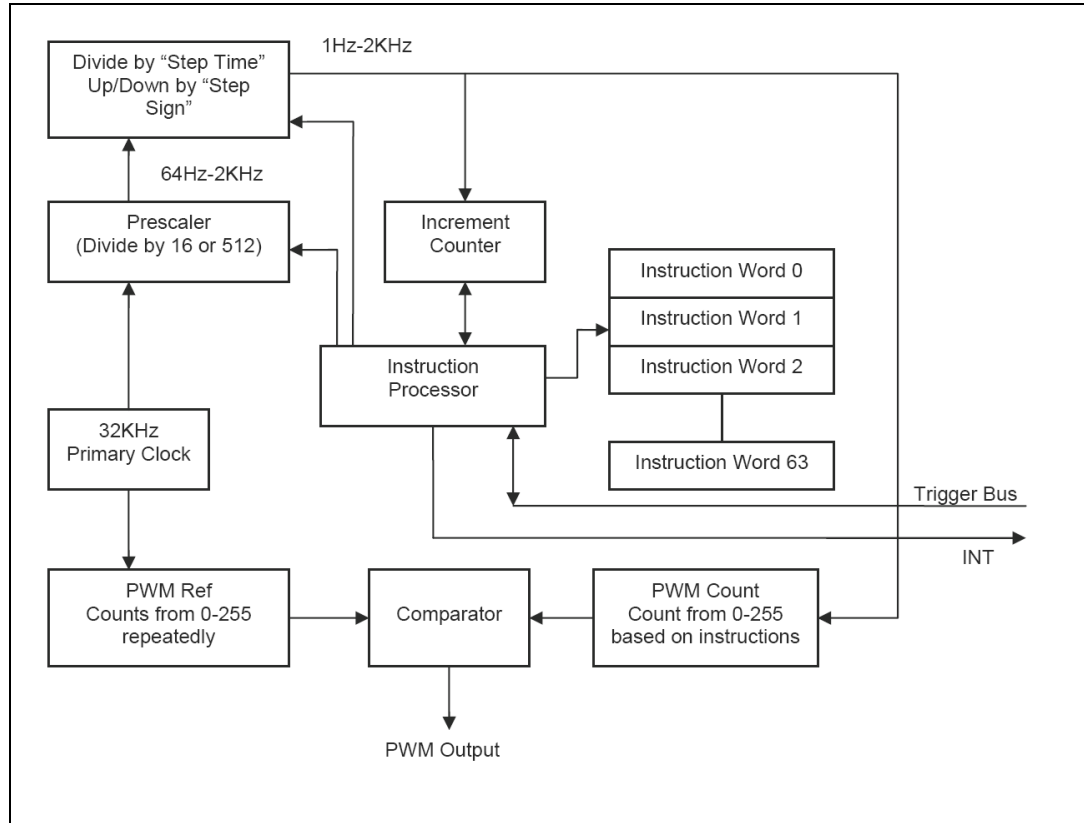

Instructions are downloaded into the memory via the I2C connection.

11.1 Registers in the PWM controller

The main system registers are:

Table 31. Main system registers

Address	Register Name	Description	Auto-Increment (during Read/Write)
0x30	PWMCS	PWM Control and Status register	Yes
0x38	PWMIC0	PWM instructions are initialized through this data port. Every instruction is 16-bit width and therefore, the MSB of the first word is written first, then, followed by LSB of the first word. Subsequently, MSB of second word and LSB of second word and so on.	No
0x39	PWMIC1	PWM instructions are initialized through this data port. Every instruction is 16-bit width and therefore, the MSB of the first word is written first, then, followed by LSB of the first word. Subsequently, MSB of second word and LSB of second word and so on.	No
0x3A	PWMIC2	PWM instructions are initialized through this data port. Every instruction is 16-bit width and therefore, the MSB of the first word is written first, then, followed by LSB of the first word. Subsequently, MSB of second word and LSB of second word and so on.	No

11.2 PWM control and status register (PWMCS)

Bit	7	6	5	4	3	2	1	0
	Reserved		II2	II1	II0	EN2	EN1	EN0
Read/Write	R	R	R	R	R	RW	RW	RW
Reset Value	0	0	0	0	0	0	0	0

Table 32. Bit description

Bits	Name	Description
0	EN0	PWM Channel 0 Enable bit. ‘1’ – Enable the PWM Channel 0 ‘0’ – Reset the PWM Channel 0. Only when the PWM channel is in reset state, the stream of commands can be written into its data port, which in this case is PWM_Command_Channel_0.
1	EN1	PWM Channel 1 Enable bit. ‘1’ – Enable the PWM Channel 1 ‘0’ – Reset the PWM Channel 1. Only when the PWM channel is in reset state, the stream of commands can be written into its data port, which in this case is PWM_Command_Channel_1.
2	EN2	PWM Channel 2 Enable bit. ‘1’ – Enable the PWM Channel 2 ‘0’ – Reset the PWM Channel 2. Only when the PWM channel is in reset state, the stream of commands can be written into its data port, which in this case is PWM_Command_Channel_2.
3	II0	PWM Invalid Instruction Status bit for PWM Channel 0 ‘0’ – No invalid command encountered during the instruction execution. ‘1’ – Invalid command encountered and this puts the PWM Channel 0 into reset state.
4	II1	PWM Invalid Instruction Status bit for PWM Channel 1 ‘0’ – No invalid command encountered during the instruction execution. ‘1’ – Invalid command encountered and this puts the PWM Channel 1 into reset state.
5	II2	PWM Invalid Instruction Status bit for PWM Channel 2 ‘0’ – No invalid command encountered during the instruction execution. ‘1’ – Invalid command encountered and this puts the PWM Channel 2 into reset state.

11.3 PWM instruction channel x (PWMICx)

This PWMICx is the dataport that allows the instructions to be loaded into the PWM channel. The loading of the instructions is achieved by continuously writing to this dataport. As this dataport address falls on the non-auto increment region, continuous write operation on I²C will write into the same dataport address. The 'x' value is from 0 to 2 as there are 3 independent PWM channels. To access these dataports, the corresponding ENx in the PWMCS register must be set to 0 first to put the PWM channel in reset state.

Bit	7	6	5	4	3	2	1	0
	IB7	IB6	IB5	IB4	IB3	IB2	IB1	IB0
Read/Write	RW	RW	RW	RW	RW	RW	RW	RW
Reset Value	0	0	0	0	0	0	0	0

Table 33. Pin description

Bits	Name	Description
7:0	IB[x]	PWM Instruction Channel x, where x is 7 to 0 As an instruction is 16-bit width, writing the instruction into this 8-bit PWMICx dataport requires two 8-bit data write. The most significant byte of the 16-bit instruction is to be written in first and followed by the least significant byte of the instruction. The same effect applies to the read operation.

12 PWM commands

The STMPE2401 PWM Controller works as a simple MCU, with program space of 64 instructions and a simple instruction set. The instructions are all 16 bits in length. The 3 most significant bits are used to identify the commands.

Table 34. PWM commands

Instruction	Description
RAMP	This instruction starts the PWM counters and set the pwm_x_out with the result from the counting.
Set Maximum (SMAX)	Load the PWM counter with the value of 0xff and the pwm_x_out will result in logic level low.
Set Minimum (SMIN)	Load the PWM counter with the value of 0x0 and the pwm_x_out will result in logic level high.
Go to Start (GTS)	Branch to the address 0x0 and execute from 0x0 and onwards.
BRANCH	Branch to a relative or an absolute address to execute with the looping capability. There are 4 loop counters available and these allow 4 nested loops.
END	End the instruction execution by resetting and interrupting to the host.
Trigger (TRIG)	Capable of waiting as well as sending triggers to another PWM channel.

Table 35. Identification of instructions

Instruction	Bit 15	Bit 14	Bit 13
Ramp	0	-	-
SetFullScale	0	-	-
SetMinimum	0	-	-
GoToStart	0	-	-
Branch	1	0	1
End	1	1	0
Trigger	1	1	1
Reserved	1	0	0

Table 36. Instruction

Instruction	Bit															Timing in 2kHz						
	15	14	13	12	11	10	9	8	7	6	5	4	3	2	1		0					
RAMP	0	Prescale 0=16 1=512	Step Time 0 - 63 0 = immediate action					Sign 0=step-up 1=step-down	Increment 1 – 126					Increment value of 0 is not allowed. prescale = 16 :- Consumes [(step time) ⁽¹⁾ (increment)] cycles prescale = 512 :- Consumes [(32) ⁽¹⁾ (step time) ⁽¹⁾ (increment)] cycles								
SMAX	0	x ⁽²⁾	0					0	127					Consumes 1 cycle								
SMIN	0	x ⁽²⁾	0					1	127					Consumes 1 cycle								
GTS	0	0	0					0	0					Consumes 1 cycle								
BRANCH	1	01	Loop Counter to use 0 - 3			Loop Count 0 – 15 0 = forever loop			0=absolute step size 1=relative step size ⁽¹⁾	Step Size 0 – 63 ⁽¹⁾					Consumes 1 cycle Once the loop count has been reached, the loop counter resets.							
END	1	10	Interrupt to host	Reset instruction counter and output level to zero		RESERVED										Consumes 1 cycle						
TRIG	1	11	Wait for Trigger on channel 0 – 2 Continues if all selected triggers present. Each bit signifies wait for the corresponding channel.					Send Trigger on channel 0 – 2 Continues if no Wait for Trigger in this instruction.					x ⁽²⁾					Consumes 1 or more cycles				
reserved	1	00	RESERVED												Reserved.							

1. Absolute Branch jumps to the absolute address (relative to address 0x0) using the value of step size. The Relative Branch jumps in a backward manner relative to the current address location, ie. 1 means jump to the previous instruction location and 0 means NOP.

2. Don't care.

In order to enable a PWM channel, the programming sequence below should be observed.

- The ENx of the PWMCS register should be kept in '0'. By default, it has a value of '0'.
- Loads the instructions into the PWM channel x by writing the corresponding PWMICx.
- The PWM channel x has a 64-word depth (16-bit width). Any instructions of size less than or equal to 64 words can be loaded into the channel. Any attempt to load beyond 64 words will result in internal address pointer to roll-over (0x1f \diamond 0x00) and the excess instructions to be over-written into the first address location of the channel and onwards.
- After the instructions are loaded in, then, the PWM channel x can be enabled by setting a '1' to the ENx bit.
- Enables the corresponding interrupt mask bit to allow interruption to the host.

13 Keypad controller

The main operations of the keypad controller are controlled by four dedicated key controllers that support up to four simultaneous dedicated key presses and a key scan controller and two normal key controllers that support a maximum of 12x8 key matrix with detection of two simultaneous key presses.

Four of the column inputs can be configured as dedicated keys through the setting of Dkey0~3 bits of KPC_ctrl register.

The normal key matrix size is configurable through the setting of KPC_row and KPC_col registers. The scanning of each individual row output and column input can be enabled or masked to support a key matrix of variable size from 1x1 to 12x8.

The operation of the keypad controller is enabled by the SCAN bit of KPC_ctrl register. Every key activity detected will be de-bounced for a period set by the DB_0~7 bits of KPC_ctrl register before a key press or key release is confirmed and updated into the output FIFO. The key data, indicating the key coordinates and its status (up or down), is loaded into the FIFO at the end of a specified number of scanning cycles (set by ScanCount0~3 bits of KPC_row_msb register). An interrupt will be generated when a new set of key data is loaded. The FIFO has a capacity for four sets of key data. Each set of key data consists of three bytes of information when any of the four dedicated keys is enabled. It is reduced to two bytes when no dedicated key is involved. When the FIFO is full before its content is read, an overflow signal will be generated while the FIFO will continue to hold its content but forbid loading of new key data set.

Figure 9. Keypad controller

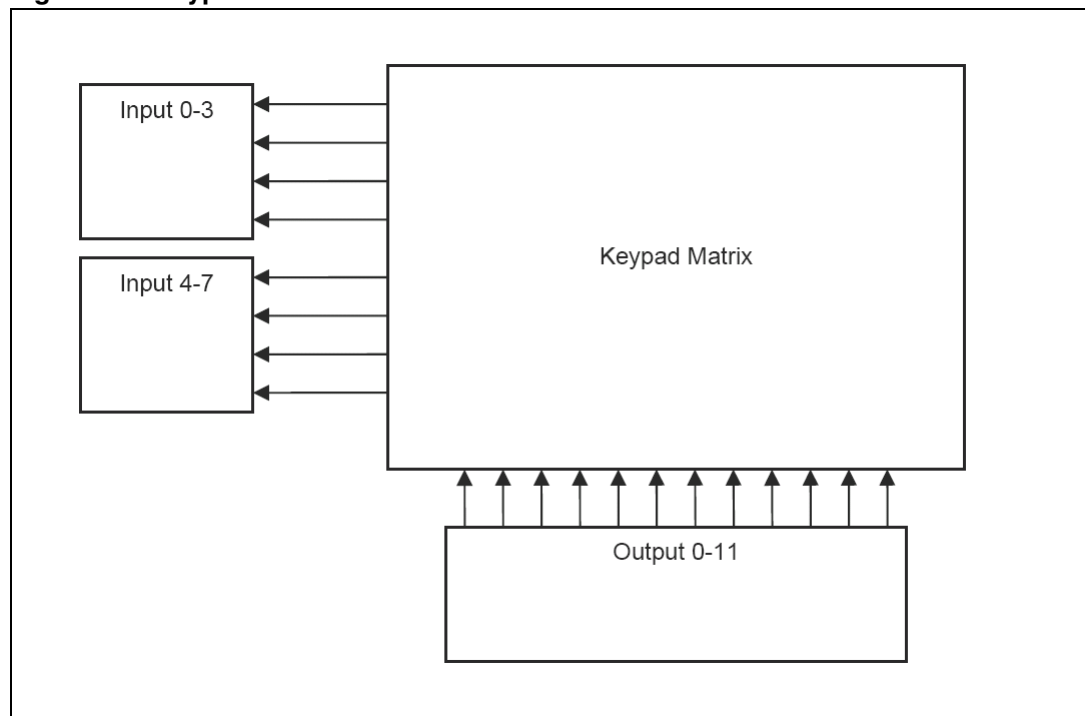

The keypad column inputs enabled by the KPC_col register are normally 'HIGH', with the corresponding input pins pulled up by resistors internally. After reset, all the keypad row outputs enabled by the KPC_row register are driven 'LOW'. If a key is pressed, its corresponding column input will become 'LOW' after making contact with the 'LOW' voltage on its corresponding row output.

Once the key scan controller senses a 'LOW' input on any of the column inputs, the scanning cycles will then start to determine the exact key that has been pressed. The twelve row outputs will be driven 'LOW' one by one (if the row output is enabled) during each scanning cycle. While one row is driven 'LOW', the other rows are driven 'HIGH'. (The pull-ups and pull-downs of row outputs are always disabled). If there is any column input sensed as 'LOW' when a row is driven 'LOW', the key scan controller will then decode the key coordinates (its corresponding row number and column number), save the key data into a de-bounce buffer if available, confirm if it is a valid key press after de-bouncing, and update the key data into output data FIFO if valid.

13.1 Registers in keypad controller

Table 37. Register in keypad controller

Address	Register name	Description	Auto-Increment (during sequential R/W)
0x60	KPC_col	Keypad column scanning register	Yes
0x61	KPC_row_msb	Keypad row scanning register	Yes
0x62	KPC_row_lsb		Yes
0x63	KPC_ctrl_msb	Keypad control register	Yes
0x64	KPC_ctrl_lsb		Yes
0x68	KPC_data_byte0	Keypad data register	No
0x69	KPC_data_byte1		No
0x6A	KPC_data_byte2		No

13.2 KPC_col register

Table 38. KPC_col Register

Bit	7	6	5	4	3	2	1	0
Name	Input Column 0 ~ 7							
Read/Write	W	W	W	W	W	W	W	W
Reset Value	0	0	0	0	0	0	0	0
Bit	Name		Description					
7	Input Column 7		'1' to turn on scanning of column 7; '0' to turn off					
6	Input Column 6		'1' to turn on scanning of column 6; '0' to turn off					
5	Input Column 5		'1' to turn on scanning of column 5; '0' to turn off					
4	Input Column 4		'1' to turn on scanning of column 4; '0' to turn off					
3	Input Column 3		'1' to turn on scanning of column 3; '0' to turn off					
2	Input Column 2		'1' to turn on scanning of column 2; '0' to turn off					
1	Input Column 1		'1' to turn on scanning of column 1; '0' to turn off					
0	Input Column 0		'1' to turn on scanning of column 0; '0' to turn off					

13.3 KPC_row_msb register

Table 39. KPC_row_msb register

Bit	7	6	5	4	3	2	1	0
Name	ScanPW1	ScanPW0	-	-	Output Row 8 ~ 11			
Read/Write	-	-	-	-	W	W	W	W
Reset Value	1	1	0	0	0	0	0	0
Bit	Name		Description					
7	ScanPW1		Pulse width setting of keypad scanning. Use "11" at all times					
6	ScanPW0							
5	-		-					
4	-		-					
3	Output Row 11		'1' to turn on scanning of row 11; '0' to turn off					
2	Output Row 10		'1' to turn on scanning of row 10; '0' to turn off					
1	Output Row 9		'1' to turn on scanning of row 9; '0' to turn off					
0	Output Row 8		'1' to turn on scanning of row 8; '0' to turn off					

13.4 KPC_row_lsb register

Table 40. KPC_row_lsb register

Bit	7	6	5	4	3	2	1	0
Name	output Row 0 ~ 7							
Read/Write	W	W	W	W	W	W	W	W
Reset Value	0	0	0	0	0	0	0	0
Bit	Name		Description					
7	output Row 7		'1' to turn on scanning of row 7; '0' to turn off					
6	output Row 6		'1' to turn on scanning of row 6; '0' to turn off					
5	output Row 5		'1' to turn on scanning of row 5; '0' to turn off					
4	output Row 4		'1' to turn on scanning of row 4; '0' to turn off					
3	output Row 3		'1' to turn on scanning of row 3; '0' to turn off					
2	output Row 2		'1' to turn on scanning of row 2; '0' to turn off					
1	output Row 1		'1' to turn on scanning of row 1; '0' to turn off					
0	output Row 0		'1' to turn on scanning of row 0; '0' to turn off					

13.5 KPC_ctrl_msb register

Table 41. KPC_ctrl_msb register

Bit	7	6	5	4	3	2	1	0
Name	ScanCount0 ~ 3				DKey_0 ~ 3			
Read/Write	W	W	W	W	W	W	W	W
Reset Value	0	0	0	0	0	0	0	0
Bit	Name		Description					
7	ScanCount3		Number of key scanning cycles elapsed before a confirmed key data is updated into output data FIFO (0 ~ 15 cycles)					
6	ScanCount2							
5	ScanCount1							
4	ScanCount0							
3	DKey_3		Set '1' to use Input Column 3 as dedicated key					
2	DKey_2		Set '1' to use Input Column 2 as dedicated key					
1	DKey_1		Set '1' to use Input Column 1 as dedicated key					
0	DKey_0		Set '1' to use Input Column 0 as dedicated key					

13.6 KPC_ctrl_Isb register

Table 42. KPC_ctrl_Isb register

Bit	7	6	5	4	3	2	1	0
Name	DB_0 ~ 5							SCAN
Read/Write	W	W	W	W	W	W	W	W
Reset Value	0	0	0	0	0	0	0	0
Bit	Name		Description					
7	DB_6		0-128ms of de-bounce time					
6	DB_5							
5	DB_4							
4	DB_3							
3	DB_2							
2	DB_1							
1	DB_0							
0	SCAN		'1' to start scanning; '0' to stop					

13.7 Data registers

The KPC_DATA register contains three bytes of information. The first two bytes store the key coordinates and status of any two keys from the normal key matrix, while the third byte store the status of dedicated keys.

Table 43. KPC_data_byte0 register

Bit	7	6	5	4	3	2	1	0
Name	Up/Down	R3	R2	R1	R0	C2	C1	C0
Read/Write	R	R	R	R	R	R	R	R
Reset Value	1	1	1	1	1	0	0	0
Bit	Name		Description					
7	Up/Down		'0' for key-down, '1' for key-up					
6	R3		row number of key 1 (valid range : 0-11) 0x1111 for No Key					
5	R2							
4	R1							
3	R0							
2	C2		column number of key 1 (valid range : 0-7)					
1	C1							
0	C0							

Table 44. KPC_data_byte1 register

Bit	7	6	5	4	3	2	1	0
Name	Up/Down	R3	R2	R1	R0	C2	C1	C0
Read/Write	R	R	R	R	R	R	R	R
Reset Value	1	1	1	1	1	0	0	0
Bit	Name		Description					
7	Up/Down		'0' for key-down, '1' for key-up					
6	R3		row number of key 2 (valid range : 0-11) 0x1111 for No Key					
5	R2							
4	R1							
3	R0							
2	C2		column number of key 2 (valid range : 0-7)					
1	C1							
0	C0							

Table 45. KPC_data_byte2 register

Bit	7	6	5	4	3	2	1	0
Name	-	-	-	-	Dedicated Key 0 ~ 3			
Read/Write	R	R	R	R	R	R	R	R
Reset Value	0	0	0	0	1	1	1	1
Bit	Name		Description					
7	-		-					
6	-		-					
5	-		-					
4	-		-					
3	Dedicated Key 3		'0' for key-down, '1' for key-up					
2	Dedicated Key 2		'0' for key-down, '1' for key-up					
1	Dedicated Key 1		'0' for key-down, '1' for key-up					
0	Dedicated Key 0		'0' for key-down, '1' for key-up					

13.7.1 Resistance

Maximum resistance between keypad output and keypad input, inclusive of switch resistance, protection circuit resistance and connection, must be less than 3.2 K Ω

13.7.2 Using the keypad controller

Before enabling the keypad controller operation, proper setup should be done by configuring the input and output ports involved. This is achieved by programming the corresponding GPIO control registers that determine the port direction and the necessary internal pull-up or pull-down. For the GPIO ports that are used as keypad inputs, internal pull-up should be enabled. For those that are used as keypad outputs, no internal pull-up or pull-down should be enabled.

The scanning of column inputs should then be enabled for those GPIO ports that are configured as keypad inputs by writing '1's to the corresponding bits in the KPC_col register. If any of the first three column inputs is to be used as dedicated key input, the corresponding bits in the KPC_ctrl_msb register should be set to '1'. The bits in the KPC_row_msb and KPC_row_lsb registers should also be set correctly to enable the row output scanning for the corresponding GPIO ports programmed as keypad outputs.

The scan count and de-bounce count should also be programmed into the keypad control registers before enabling the keypad controller operation. To enable the keypad controller operation, the Enable_KPC bit in the system control register must be set to '1' to provide the required clock signals. The keypad controller will then start its operation by setting the SCAN bit in the KPC_ctrl_lsb register to '1'.

The keypad controller operation can be disabled by setting the SCAN bit back to '0'. To further reduce the power consumption, the clock signals can be cut off from the keypad controller by setting the Enable_KPC bit to '0'.

ScanCount value is programmable to any value between 1-15 by writing into the scancount register. If scan count is programmed to N, the Keypad Controller scans the entire matrix for N times, collecting up to 2 matrix key and 4 dedicated keys, loads the keys into 1 set of keypad data buffer and interrupts the host system.

14 Rotator controller

Rotator controller consists of 3 terminal, each capable of becoming an input with internal pull-up, or and output. At any moment, 2 terminals are inputs and one terminal is output.

Figure 10. Rotator controller

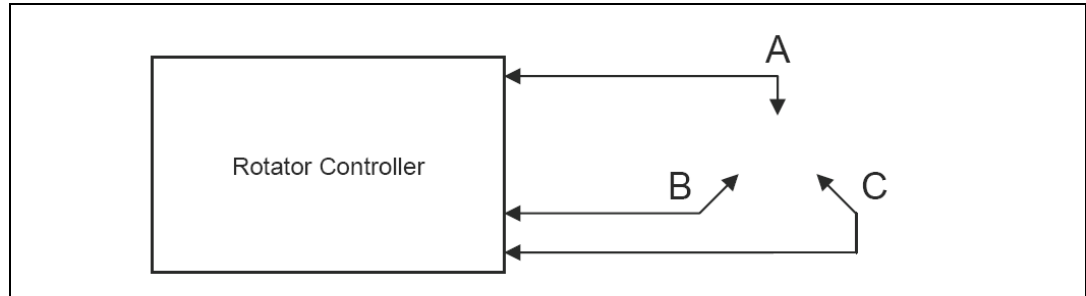

The Rotator Controller is responsible for the detection of the direction of rotator and the reporting of these direction sequences. The direction of a rotator can be either up or down. A rotator has 3 contacts and detection of shorts on these contacts is used to determine the direction of rotation. Following diagram shows the definition of the direction of rotation and how the FSM states and driven outputs correspond to rotation.

Table 46. 3 possible conditions: A-B short, B-C short, C-A short.

LO Input	Current State				Next State				Result
	State	Output	Input	Input	State	Output	Input	Input	
C	1	A	B	C	2	B	A	C	Up
B	1	A	B	C	3	C	A	B	Down
A	2	B	A	C	3	C	A	B	Down
C	2	B	A	C	1	A	B	C	Up
A	3	C	A	B	2	B	A	C	Up
B	3	C	A	B	1	A	B	C	Down

Figure 11. Possible conditions

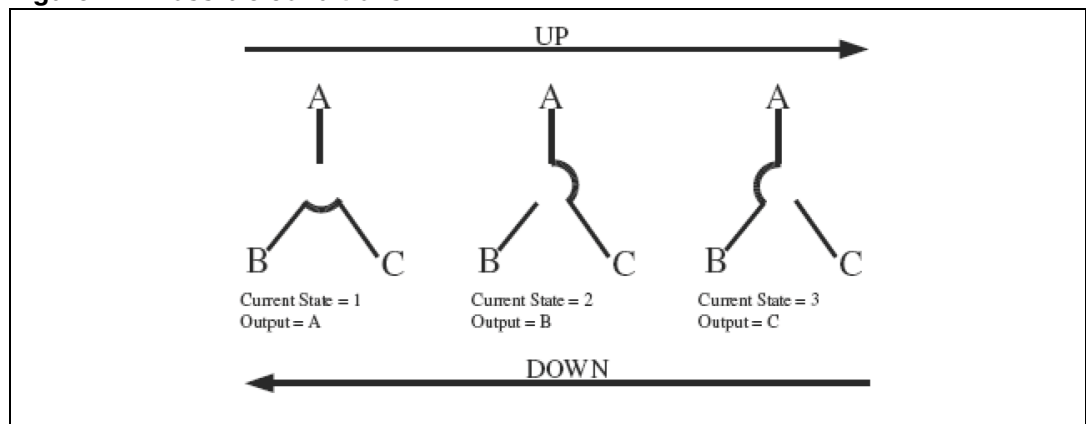

Table 47. Registers for rotator control

Address	Register name	Register Size
0x70	Rotator_Control	8
0x72	Rotator_Buffer	8

14.1 Rotator_Control

Bit	7	6	5	4	3	2	1	0
	Start_FSM	Reserved						
Read/Write	RW	R	R	R	R	R	R	R
Reset Value	0	0	0	0	0	0	0	0

Bits	Name	Description
7	Start_FSM	Rotator FSM start bit. '1' – Activate the FSM '0' – Stop sampling rotator symbols

14.2 Rotator_Buffer

Bit	7	6	5	4	3	2	1	0
	Symbol_Type	Symbol_Count						
Read/Write	R	R	R	R	R	R	R	R
Reset Value	0	0	0	0	0	0	0	0

Bits	Name	Description
7	Symbol_Type	Symbol type to be reported '1' – Down '0' – Up
6~0	Symbol_Count	Number of symbols of the type specified by bit 7 Minimum of 0 (b'0000000) to Maximum of 127 (b'1111111)

The host should do the following on the I²C bus to start the Rotator controller:

1. The host writes to GPIO Controller to configure the PU/PD bit and select the Rotator Bits on the relevant IO.
2. Write Rotator_Control data register to start the rotator controller. A maximum of 2 rotations later, the correct initial state on the rotator FSM is obtained. Scanning for rotator movement continues.
3. The host waits for interrupt from the rotator controller.
4. The host reads Rotator_Buffer
5. The host can stop rotator controller operation by writing to Rotator_Control register.

15 Miscellaneous features

15.1 Reset

STMPE2401 is equipped with an internal POR circuit that holds the device in reset state, until the clock is steady and V_{CC} input is valid. Host system may choose to reset the STMPE2401 by asserting Reset_N pin.

15.2 Under voltage lockout

STMPE2401 is equipped with an internal UVLO circuit that generates a RESET signal, when the main supply voltage falls below the allowed threshold.

15.3 Clock output

STMPE2401 provides a buffered 32KHz clock output at one of the GPIO as alternate function. This clock could be used for cascading of multiple port expander devices, using just 1 XTAL unit.

16 Mechanical data

In order to meet environmental requirements, ST offers these devices in ECOPACK® packages. These packages have a Lead-free second level interconnect . The category of second level interconnect is marked on the package and on the inner box label, in compliance with JEDEC Standard JESD97. The maximum ratings related to soldering conditions are also marked on the inner box label. ECOPACK is an ST trademark. ECOPACK specifications are available at: www.st.com

Table 48. TFBGA Mechanical data

Dim.	mm.			inch		
	Min	Typ	Max	Min	Typ	Max
A	1.1	1	1.16	0.043	0.039	0.046
A1			0.25			0.010
A2		0.78	0.86		0.031	0.034
b	0.30	0.25	0.35	0.012	0.010	0.014
D	3.60	3.50	3.70	0.142	0.138	0.146
D1	3.50			0.138		
E	3.50	3.60	3.70	0.142	0.138	0.146
E1	2.50			0.098		
e	0.50			0.020		
F	0.55			0.022		

Figure 12. Package dimensions

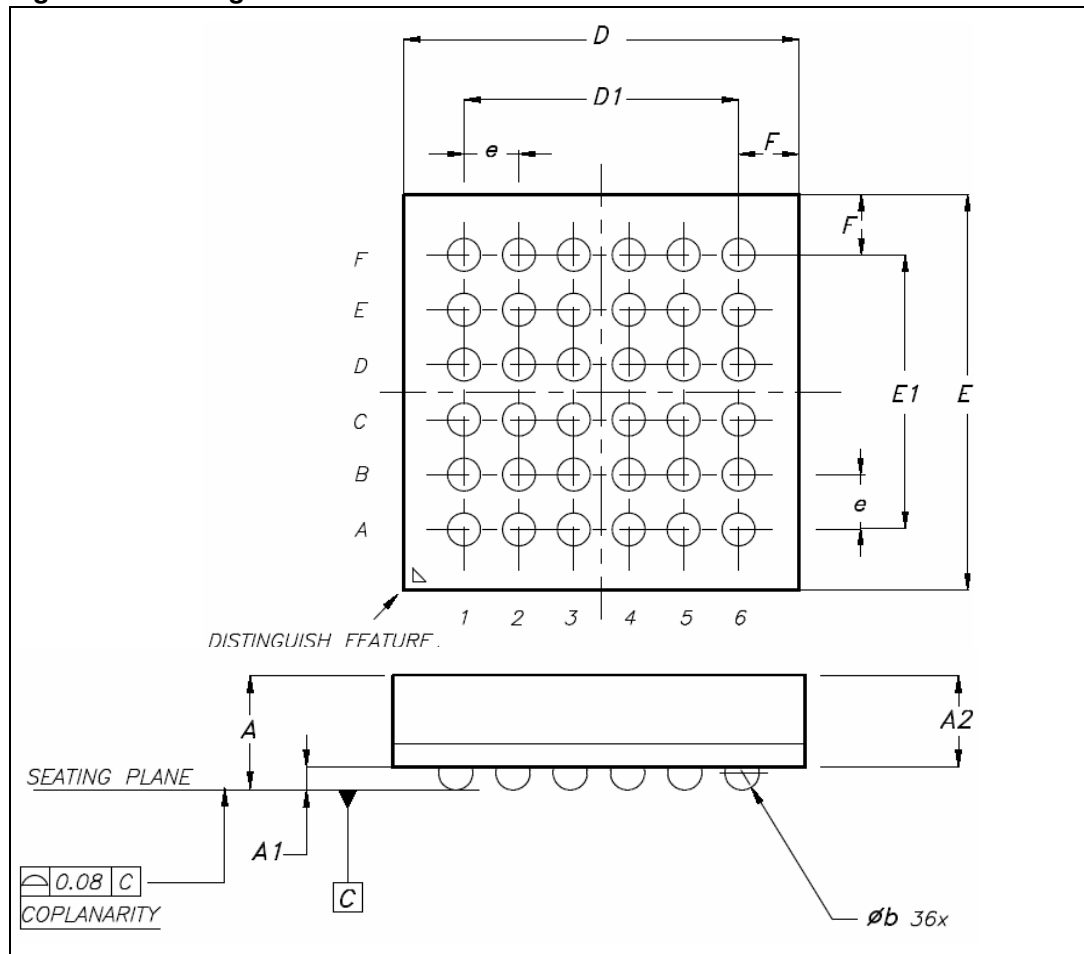

Figure 13. Recommended footprint

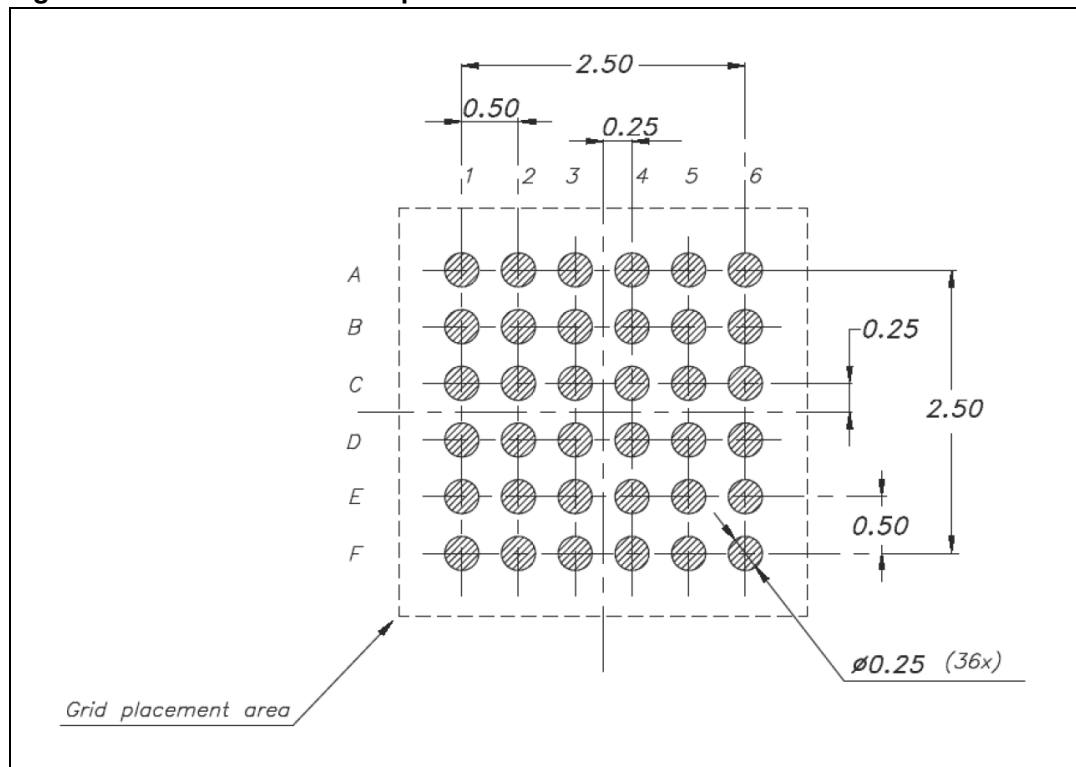
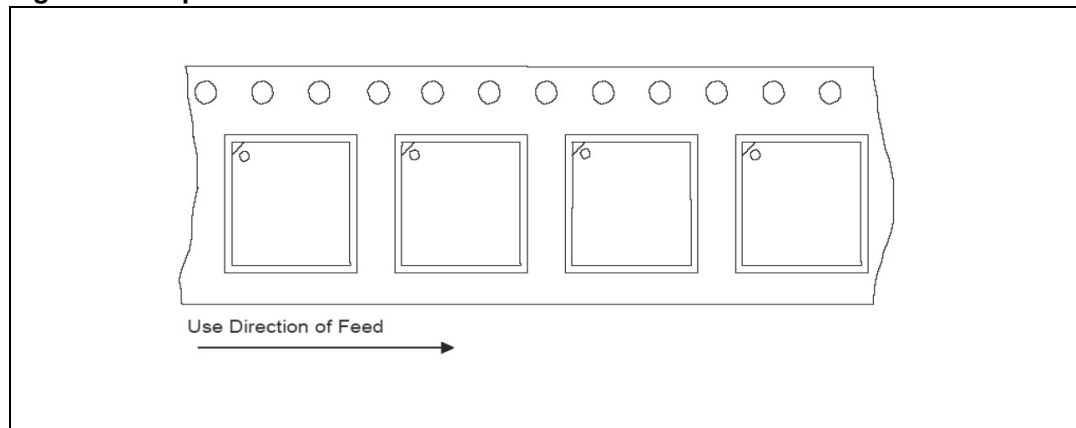

Figure 14. Tape and reel information



17 Revision history

Table 49. Revision history

Date	Revision	Changes
08-Jan-2007	1	Initial release
29-May-2007	2	Cover page updated

Please Read Carefully:

Information in this document is provided solely in connection with ST products. STMicroelectronics NV and its subsidiaries ("ST") reserve the right to make changes, corrections, modifications or improvements, to this document, and the products and services described herein at any time, without notice.

All ST products are sold pursuant to ST's terms and conditions of sale.

Purchasers are solely responsible for the choice, selection and use of the ST products and services described herein, and ST assumes no liability whatsoever relating to the choice, selection or use of the ST products and services described herein.

No license, express or implied, by estoppel or otherwise, to any intellectual property rights is granted under this document. If any part of this document refers to any third party products or services it shall not be deemed a license grant by ST for the use of such third party products or services, or any intellectual property contained therein or considered as a warranty covering the use in any manner whatsoever of such third party products or services or any intellectual property contained therein.

UNLESS OTHERWISE SET FORTH IN ST'S TERMS AND CONDITIONS OF SALE ST DISCLAIMS ANY EXPRESS OR IMPLIED WARRANTY WITH RESPECT TO THE USE AND/OR SALE OF ST PRODUCTS INCLUDING WITHOUT LIMITATION IMPLIED WARRANTIES OF MERCHANTABILITY, FITNESS FOR A PARTICULAR PURPOSE (AND THEIR EQUIVALENTS UNDER THE LAWS OF ANY JURISDICTION), OR INFRINGEMENT OF ANY PATENT, COPYRIGHT OR OTHER INTELLECTUAL PROPERTY RIGHT.

UNLESS EXPRESSLY APPROVED IN WRITING BY AN AUTHORIZED ST REPRESENTATIVE, ST PRODUCTS ARE NOT RECOMMENDED, AUTHORIZED OR WARRANTED FOR USE IN MILITARY, AIR CRAFT, SPACE, LIFE SAVING, OR LIFE SUSTAINING APPLICATIONS, NOR IN PRODUCTS OR SYSTEMS WHERE FAILURE OR MALFUNCTION MAY RESULT IN PERSONAL INJURY, DEATH, OR SEVERE PROPERTY OR ENVIRONMENTAL DAMAGE. ST PRODUCTS WHICH ARE NOT SPECIFIED AS "AUTOMOTIVE GRADE" MAY ONLY BE USED IN AUTOMOTIVE APPLICATIONS AT USER'S OWN RISK.

Resale of ST products with provisions different from the statements and/or technical features set forth in this document shall immediately void any warranty granted by ST for the ST product or service described herein and shall not create or extend in any manner whatsoever, any liability of ST.

ST and the ST logo are trademarks or registered trademarks of ST in various countries.

Information in this document supersedes and replaces all information previously supplied.

The ST logo is a registered trademark of STMicroelectronics. All other names are the property of their respective owners.

© 2007 STMicroelectronics - All rights reserved

STMicroelectronics group of companies

Australia - Belgium - Brazil - Canada - China - Czech Republic - Finland - France - Germany - Hong Kong - India - Israel - Italy - Japan - Malaysia - Malta - Morocco - Singapore - Spain - Sweden - Switzerland - United Kingdom - United States of America

www.st.com

